

Control Unit Exclusive for Light Curtain
SF-C13

MJE-SFC13 No.0050-03V

Thank you very much for purchasing Panasonic products. Please read this Instruction Manual carefully and thoroughly for the correct and optimum use of this product. Kindly keep this manual in a convenient place for quick reference. English and Japanese are original instructions.

WARNING

When using this product as a safety equipment for a press machine in Japan, always use this product, SF4B-□-01<V2> and cable with protective tube SFPB-□ in combination. Other combinations are not acceptable as a safety equipment for a press machine.

1 OUTLINE

- This product is a control unit exclusive for the light curtain conforming to European / North American safety standards and Japanese safety standards for press machines.
- This device complies with the following standards / regulations.
 - <EU Directives>**
EU Machinery Directive 2006/42/EC
EMC Directive 2004/108/EC
RoHS Directive 2011/65/EU
 - <European Standards>**
EN 61496-1 (Type 4), EN 55011, EN 50178
EN ISO 13849-1: 2008 (Category 4, PL_e)
 - <International Standards>**
IEC 61496-1 (Type 4), ISO 13849-1: 2006 (Category 4, PL_e)
 - <Japanese Industrial Standards (JIS)>**
JIS B 9704-1 (Type 4), JIS B 9705-1 (Category 4)
 - <Standards in US / Canada>**
ANSI/UL 61496-1 (Type 4), ANSI/UL 508, UL 1998 (Class 2)
CAN/CSA C22.2 No.14, CAN/CSA C22.2 No.0.8
 - <Regulations in US>**
OSHA 1910.212, OSHA 1910.217(C), ANSI B11.1 to B11.19, ANSI/RIA 15.06
Regarding EU Machinery Directive, a Notified Body, TÜV SÜD, has certified with the type examination certificate. With regard to the standards in US / Canada, a NRTL, UL (Underwriters Laboratories Inc.) has certified for cULus Listing Mark.
 - <Regulations in Korea>**
S1-G-35-2005, S2-W-11-2003
The S-mark certificate has been certified by Korea Occupational Safety & Health Agency (KOSHA).

<Reference>
The conformity to JIS, OSHA and ANSI for this device has been evaluated by ourselves.

2 FUNCTIONAL DESCRIPTION

- Power indicator (Green)
- Safety output indicator (Green)
- Interlock indicator (Yellow)
- Fault indicator (Yellow)

| No. | Designation | Description |
|-----|---|---|
| 1 | Power indicator (Ui) (Green) | Lights up when the power is supplied. |
| 2 | Safety output indicator (OUT) (Green) | Lights up when the safety output is "close." |
| 3 | Interlock indicator (INTER_LOCK) (Yellow) | Lights up when the safety output is "open." |
| 4 | Fault indicator (FAULT) (Yellow) | Blinks when an error occurs. For details, refer to "TROUBLESHOOTING." |

3 INSTALLATION POSITION / DIRECTION / METHOD

- Use the 35mm width DIN rail to install the unit.
- The installation position / direction is not basically limited.
- Please fix this product with the DIN rail stopper MS-DIN-E (optional) after installing the product on to the 35mm width DIN rail.
- If two or more units are placed side by side, make sure to space them at least 5mm apart. In case they are mounted close to each other, lower the rated operation current of the safety output depending on the ambient temperature, referring the right graph.
- Always install this product in a control panel having an IP54 or higher protective structure.

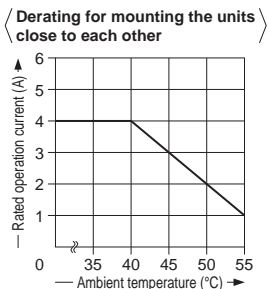

4 I/O CIRCUIT DIAGRAMS

- The following cables are recommended for power supply / output line and signal line.
Solid wire: $\phi 0.4$ to $\phi 1.2$ mm (AWG 26 to 16)
Twisted wire: 0.2 to 1.25mm² (AWG 24 to 16)
Standard stripped wire length: 11mm
- When using this product as safety equipment for press machines in Japan, be sure to use the cable with protective tube SFPB-CC□ (optional).
- For wiring the light curtain, refer to the instruction manual enclosed with the light curtain.
- When connecting a product other than this product with the light curtain, arrange a terminal block separately.

When this product is used with SF4B<V2> series, SF4B-□-01<V2> connect the external device monitor input wire (yellow-green) of SF4B<V2> series, SF4B-□-01<V2> to AUX of this device, or to the auxiliary output wire (yellow-green / black) of SF4B<V2> series, SF4B-□-01<V2>. In this case, the operation mode of the auxiliary output should be "negative-logic" of the control output* (factory setting).

<Wiring for the minus grounding (PNP setting)>

- The figure shown below is the case that this product is connected to a type 4 PNP output type light curtain. Connect the control output OSSD 1 and OSSD 2 of the light curtain to S1 and S2 respectively.

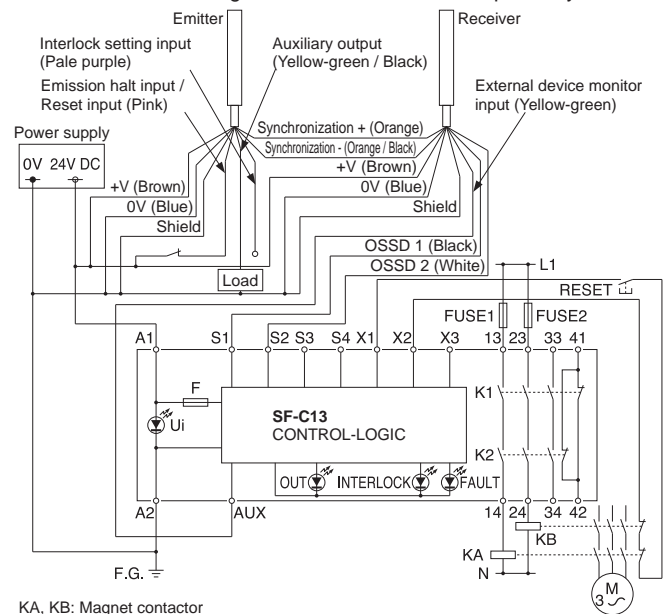

- In case of connecting a type 2 PNP output type light curtain, connect the control output (OSSD) to S1, and also put a jumper between S2 and S3.

<Wiring for the minus grounding (NPN setting)>

- The figure shown below is the case that this product is connected to a type 4 NPN output type light curtain. Connect the control output OSSD 1 and OSSD 2 of the light curtain to S4 and S2 respectively.

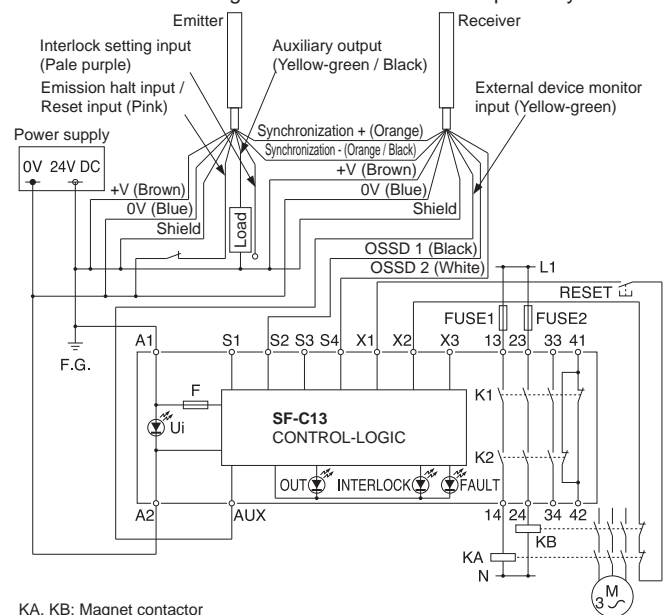

- In case of connecting a type 2 NPN output type light curtain, connect the control output (OSSD) to S4, and also put a jumper between S2 and S3.

⚠ WARNING

Install a RESET switch in place where it is possible to see all over the dangerous zone and outside of the zone.

<Manual reset>

- In case of the manual reset, configure the back check circuit between X1 and X2. If it is not necessary to check KA and KB, short-circuit KA and KB.
- Do not connect anything to X3.
- The unit operates by the trailing operation of the external reset button.
- Two or more units cannot be controlled by an external reset button. Prepare the external reset button for unit by unit.

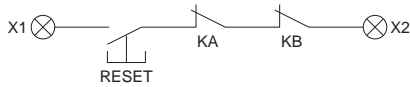

<Auto reset>

- In case of the auto reset, configure the back check circuit between X1 and X3. If it is not necessary to check KA and KB, short-circuit between X1 and X3.
- Do not connect anything to X2.
- Avoid auto-reset of the system after emergency stop by using the other control circuit. (IEC / EN 60204-1 part 9.2.5.4.2 and 10.8.3)



• Terminal arrangement diagram

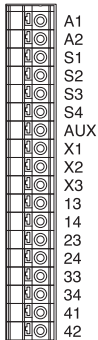

| Terminal No. | Description |
|---------------------|--|
| A1 | 24V DC |
| A2 | 0V |
| S1 to S4 | Light curtain control output (OSSD) input terminal |
| AUX | Semiconductor auxiliary output |
| X1 | Reset output terminal |
| X2 | Reset input terminal (manual) |
| X3 | Reset input terminal (automatic) |
| 13-14, 23-24, 33-34 | Safety output (NO contact x 3) |
| 41-42 | Auxiliary output (NC contact x 1) |

5 MOUNTING TERMINAL BLOCK

- When connecting to the terminal block, insert a solid wire or twisted wire (lead wire) with a ferrule (sleeve) terminal (please arrange separately) into the hole till it stops as shown in the figure right. The wire is locked when it is properly inserted. However, do not to pull the wire with excessive force, as this can cause a cable break.
- When connecting the twisted wire (lead wire) without a ferrule (sleeve) terminal, insert the wire to the innermost of the connecting hole while pressing the release button.
- When releasing the solid wire or the twisted wire (lead wire), pull the wire while pressing the release button.
- The following solid wire and twisted wire (lead wire) are recommended.
Solid wire: $\varnothing 0.4$ to $\varnothing 1.2$ mm (AWG 26 to 16)
Twisted wire (lead wire): 0.2 to 1.25 mm² (AWG 24 to 16)
Standard stripped wire length: 11mm

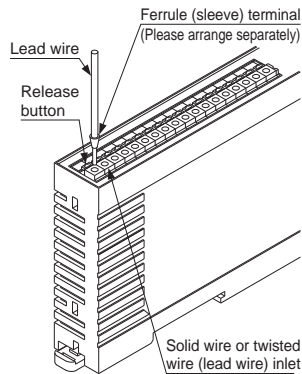

6 SHORT-CIRCUIT PROTECTION

- The power supply unit of this equipment adopts the electronic fuse which do not require any replacement.
- When the electronic fuse is operated, turn OFF the power supply, and remove the cause of overcurrent before restarting the power supply for resetting.
- The electronic fuse is not suitable to use in which the equipment is operated continuously or daily. Note that operating the equipment continuously may be unable to satisfy the specifications.

7 FUNCTIONS

- Trailing edge switching function**
- This function is to accept the input when the reset switch is pressed (contact "close") and then released (contact "open") at the manual start setting. An unexpected start-up due to the welded reset switch can be avoided.

8 MAINTENANCE

- Be sure to do maintenance before use and 6 month periodic maintenance. Refer included instruction manual of light curtain for the inspection items.
- In case replacing this device to new this device, be sure special technician to exchange it. And do daily maintenance and periodic maintenance.

9 USING THIS PRODUCT AS A SAFETY EQUIPMENT FOR A PRESS MACHINE IN JAPAN

When using this product as a safety equipment for a press machine in Japan, this product's installation, electrical wiring, inspection and maintenance must be completed by a "qualified personnel."

Qualified personnel refers to a press work supervisor, or other work supervisor who has completed special training as set forth by Industrial Safety and Health Laws, and has extensive knowledge and experience to resolve problems and any problems related to his / her duties.

- When used in combination with SF4B-□-01<V2>, this product satisfies the "Model Examination" as set forth in the Japanese Industrial Safety and Health Laws Provision 44-2 as indicated below.

[When using in combination with SF4B-□-01<V2>]

- Model examination No.:
No. TA527 (SF4B-A□-01<V2>)
No. TA528 (SF4B-F□-01<V2>, SF4B-H□-01<V2>)
- Conforming standards:
Standards for press machine or shear safety equipment structure (Ministry of Labor Notice No. 102, issued September 21, 1978)

- When using SF4B-□-01<V2> and this product as safety equipments for a press machine in Japan, a pre-work inspection and periodic inspection must be carried out by the press machine work supervisor or by the person in charge of the matters listed in Provision 134, No. 1, 2 and 4 of the Ordinance on Labor Safety and Hygiene. The press machine work supervisor, etc., must inspect the following matters before starting work, and must record and save the results.

Emitter of SF4B-□-01<V2>

- Security of mounting
- Adequacy of mounting position (safety distance and vertical position)
- Presence of damage
- Presence of abnormality in external wires
- Presence of contamination on emitter
- Security of detection state

Receiver of SF4B-□-01<V2>

- Security of mounting
- Adequacy of mounting position (safety distance and vertical position)
- Presence of damage
- Presence of abnormality in external wires
- Presence of contamination on receiver
- Security of detection state

Control unit SF-C13

- External wiring
- Indicators
- Presence of abnormal operation with switches, etc.
- Security of mounting

Refer to "Policy on Press Machine Safety Equipment Control" (Ministry of Labor, Basic Publication No. 446-2, issued on July 9, 1993) for details.

• Compatible press machines

- When using this product as a safety equipment for a press machine in Japan, the machine in which SF4B-□-01<V2> and this product are mounted must be capable of suddenly stopping from any operation point even during the operation cycle. Do not use SF4B-□-01<V2> and this product with a machine having an irregular sudden stop.
- Do not use this product with a power press having a full-rotation clutch.
- When using this product as a safety equipment for a press machine in Japan, do not use the product with a press machine that does not satisfy the following specifications.

| Item | Specifications |
|-----------------------|--|
| Model | Press machine having sudden stop device and restart prevention mechanism |
| Pressure capacity | 50,000kN or less |
| Sudden stop time | 500ms or less |
| Stroke length | Within (Protective height - Die height) |
| Range of model height | Within bolster width |

10 TROUBLESHOOTING

- The number of times the fault indicator (yellow) blinks indicates the type of error state, as follows.

| Blinking | Description of error | Cause / Remedy |
|-----------------|---|---|
| 2 times | Internal relay contact is weld | The contact was weld due to the lifetime of the relay. Replace this product by new one. |
| 3 times | Reset mode error | Wiring of the terminal X1, X2 or X3 is not correct. Check if the wiring has been correctly done. |
| 4 times or more | Influence of noise / power supply or internal circuit failure | Check the noise environment. Check the wiring, power supply voltage and voltage capacity. |

- Make sure that this product and the light curtain are connected to the common power supply.
- When the sensor doesn't operate properly even if the remedies described above are taken, contact our office.
- Interval of blinking for the fault indicator (yellow) is approx. 0.6 sec. Check the number of times the indicator blinks for approx. 2 sec. from the indicator "OFF" period.

11 SPECIFICATIONS

| Model No. | SF-C13 | |
|---|--|---|
| Connectable input device | Light curtains manufactured by Panasonic Industrial Devices SUNX | |
| Applicable standard | EN 61496-1 (Type 4), EN 55011, EN ISO 13849-1: 2008 (Category 4, PL _e) IEC 61496-1 (Type 4) ISO 13849-1: 2006 (Category 4, PL _e) JIS B 9704-1 (Type 4), JIS B 9705-1 (Category 4) ANSI/UL 61496-1 (Type 4), UL 1998 (Class 2) Ministry of Health, Labour and Welfare model examination certified product No. TA527 (SF4B-A□-01<V2>) No. TA528 (SF4B-F□-01<V2>, SF4B-H□-01<V2>) | |
| Supply voltage | 24V DC±10% Ripple P-P 10% or less | |
| Fuse rating | Built-in electronic fuse, Breaking current: 0.5A or more reset by power supply stop | |
| Safety output (Note 1) | NO contact × 3 | |
| Rated operation voltage / current | 30V DC / 4A, 230V AC / 4A Resistance load (the contact protection for inductive load) Minute current: 10mA or more (at 24V DC) | |
| Contact protection fuse rating | 4A (slow-blow) | |
| Contact material / contacts | AgSnO, Self cleaning, positively driven | |
| Contact resistance (Initial value) | 100mΩ or less | |
| Mechanical lifetime | 10,000,000 times or more (switching frequency 180 times/min.) (Note 2) | |
| Electrical lifetime | 100,000 times or more (switching frequency 20 times/min. at 230V AC / 3A, resistive load) (Note 2) | |
| Auxiliary output | Safety relay contact (NC contact) × 1 (interlocked to safety output) | |
| Rated operation voltage / current | 24V DC / 2A, Minute current: 10mA or more (at 24V DC) | |
| Contact protection fuse rating | 2A (slow-blow) | |
| Semiconductor auxiliary output (AUX terminal) | PNP open-collector transistor • Maximum source current: 60mA • Applied voltage: same as supply voltage (between the Semiconductor auxiliary output and +V) • Residual voltage: 2.3V or less (at 60mA source current) • Leak current: 2mA or less | |
| Output operation | Dark-ON | |
| Current consumption | 100mA or less (without light curtain) | |
| Application category | AC-15, DC-13 (IEC 60947-5-1) | |
| Pick-up delay | 80ms or less / 90ms or less (Auto reset / Manual reset) | |
| Response time (Drop-out delay) | 10ms or less | |
| Environmental resistance | Protection | Enclosure: IP40, Terminal: IP20 (This product must be installed into a control box having IP54 construction.) |
| | Pollution degree | 2 |
| | Ambient temperature | -10 to +55°C (No dew condensation or icing allowed) Storage: -25 to +70°C |
| | Ambient humidity | 30 to 85% RH, Storage: 30 to 95% RH |
| | Vibration resistance | No malfunction when tested with 10 to 55Hz frequency, 0.35mm amplitude in X, Y and Z directions for twenty times each |
| Overvoltage category | II | |
| B _{10d} (Note 3) | Minimum load: 20,000,000, Maximum load: 400,000 | |
| Mission time | 20 years | |
| Connection terminal | Spring gauge terminal | |
| Material | Enclosure: ABS | |
| Weight | Approx. 200g | |

Notes: 1) Timing chart of the safety output is diagram below.

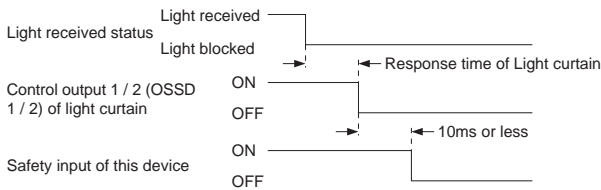

- 2) The lifetime of the switch of relay depends on type of the load, frequency of switching or environment etc.
3) Mean cycle time that 10% of parts reach dangerous failure.

12 CAUTIONS

- In case this unit is connected to a product other than the connectable input devices, this unit doesn't meet the control category 4 specified in ISO 13849-1 (EN ISO 13849-1).
- This product has been developed / produced for industrial use only.
- Make sure that the power is OFF while wiring.
- Take care that wrong wiring will damage the product.
- Verify that the supply voltage variation is within the rating.
- Take care that if a voltage exceeding the rated range is applied, or if an AC power supply is directly connected, the product may get burnt or damaged.
- The DC power supply unit must satisfy the conditions given below:
 - Power supply unit authorized in the region where this device is to be used.
 - Power supply unit SELV (safety extra low voltage) / PELV (protected extra low voltage) conforming to EMC Directive and Low-voltage Directive (In case CE Marking conformity is required.)
 - Power supply unit conforming to the Low-voltage Directive and with an output of 100VA or less.
 - The frame ground (F.G.) terminal must be connected to ground when using a commercially available switching regulator.

- Power supply unit with an output holding time of 20ms or more.
- In case a surge is generated, take countermeasures such as connecting a surge absorber to the origin of the surge.
- Power supply unit corresponding to CLASS 2 (only for requiring cULus Mark conformation).
 - Do not run the wires together with high-voltage lines or power lines or put them in the same raceway. This can cause malfunction due to induction.
 - Avoid dust, dirt, and steam.
 - Take care that the product does not come in contact with water, oil, grease, or organic solvents such as thinner, etc.
 - The seal as shown in the drawing on the right is stuck to the engagement point of unit. When the seal is peeled off or broken, this equipment will not be certified as a "Safety equipment" and will not be covered by our guarantee.
 - Note that this equipment is applicable only in the control circuit grounded in accordance with IEC 60204-1 and JIS B 9960-1, or in the control circuit in which the insulation monitor unit (ground fault detection unit) is arranged.
 - This product is suitable for indoor use only.

Do not open!
If this seal is removed or damaged, the units are not recognized as safety product.

13 DIMENSIONS (Unit: mm)

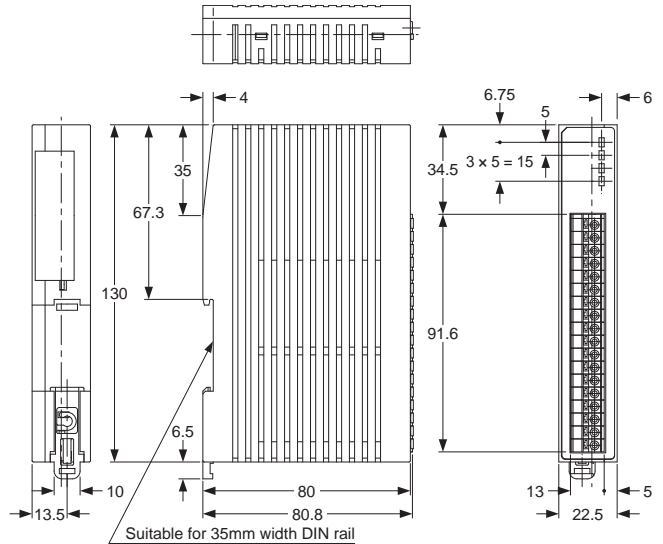

14 INTENDED PRODUCTS FOR CE MARKING

- The model listed under "11 SPECIFICATIONS" comes with CE Marking.
- As for all other models, please contact our office.

15 CE MARKING DECLARATION OF CONFORMITY

Itemized Essentials of EU Declaration of Conformity

Manufacturer's Name: Panasonic Industrial Devices SUNX Co., Ltd.
Manufacturer's Address: 2431-1, Ushiyama-cho, Kasugai, Aichi 486-0901, Japan

EU Representative's Name: Panasonic Marketing Europe GmbH
EU Representative's Address: Panasonic Testing Center
Winsbergring 15, 22525 Hamburg, Germany

Product: Exclusive Control Unit for Light Curtain
Model Name: SF-C10 Series
Trade Name: Panasonic

Application of Council Directive:

- 2006/42/EC Machinery Directive
- 2004/108/EC EMC Directive
- 2011/65/EU RoHS Directive

Harmonized standards:

- EN 61496-1: 2013
- EN ISO 13849-1: 2008
- EN 55011: 2009+A1: 2010
- EN 50581: 2012

Type Examination: Certified by TÜV SÜD Product Service GmbH
Ridlerstrasse 65 80339 München Germany

Panasonic Industrial Devices SUNX Co., Ltd.