



2700 Series High Security Anodized Alloy Housing Installation Instructions

11247E • May 2006
Copyright © 2006, GE Security Inc.

Introduction

This is the GE 2700 Series High Security Anodized Alloy Housing Installation Instructions for models 2706AP, 2706AS, 2707A, and 2707AD. The 2706AP and 2706AS have a built-in remote test feature which you may order on either the protective or supervised loop.

Installation

Position the magnet and switch so that the labels read in the same direction and the GE monogram on the magnet aligns directly with the brand on the switch. The setup gap distance is 0.4 in. (1.0 cm). Switches will operate at approximately 0.2 in. (0.5 cm) to 0.6 in. (1.5 cm) on closing and go into alarm at approximately 0.4 in. (1.0 cm) to 0.8 in. (2.0 cm) on opening. Minimum gap is 0.2 in. (0.5 cm), however, environmental conditions, such as thickness of the metal to which the switch and magnet attach, may alter gap distance. Therefore, we recommend the following installation method:

1. Bring the magnet toward the switch until an ohmmeter connected to the closed loop wires reads 0 ohms. Mark this point.
2. Bring the magnet closer to the switch until the meter reads infinity. Mark this point.
3. Position the magnet midpoint between the two marks.
4. Use the magnet template to mark the mounting holes.
5. Drill the mounting holes.
6. If a pry tamper plate is required, install it under the switch with two #6 x 3/4 in. flathead screws. Connect the gold and blue painted leads to the 24-hour circuit. The pry tamper plate is required for the certified safe and vault applications.
7. If the pry tamper plate is not used, discard the tamper plate and mount the switch directly to the surface. Be sure to connect the gold and green painted leads to the 24-hour circuit.
8. You will need to perform a remote test operation for the 2706AP and 2706AS. To do this, apply a 12 V, 5 mA max. current to the green (remote test) wires. A 24 V remote test is available on request.

Note: With the magnet positioned correctly, the switches will trip if an external magnet (67 gauss or greater) is used in an attempt to defeat the switch.

For wiring the 2707A and 2707AD, see *Figure 1*.

For wiring the 2706AP and 2706AS, see *Figure 2* on page 2.

Figure 1. Wiring for 2707A and 2707AD

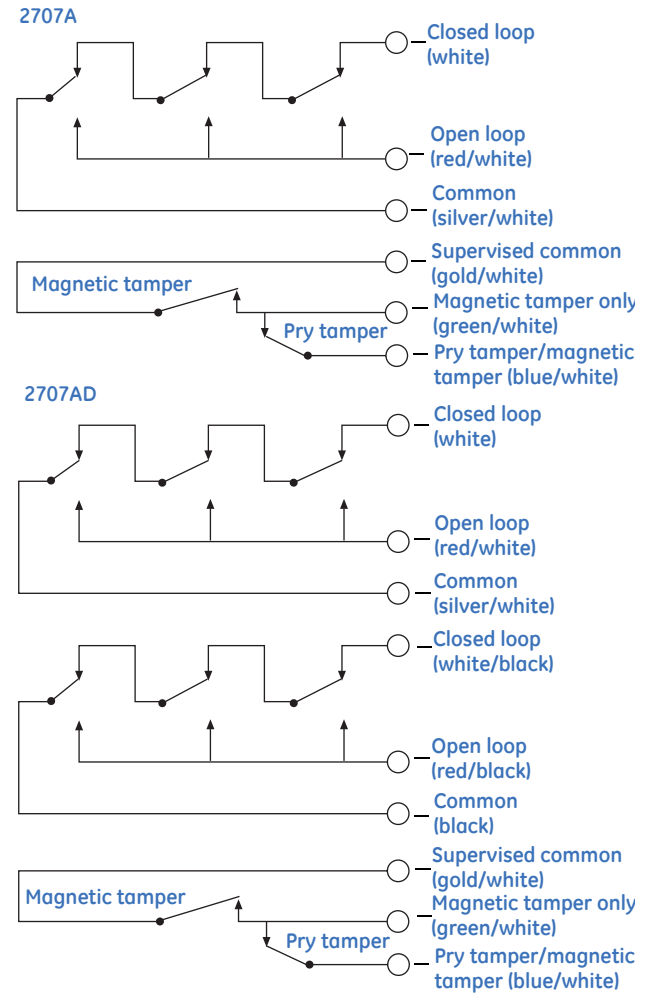

Note: Circuits shown with magnet in secure position.

Figure 2. Wiring for 2706AP and 2706AS

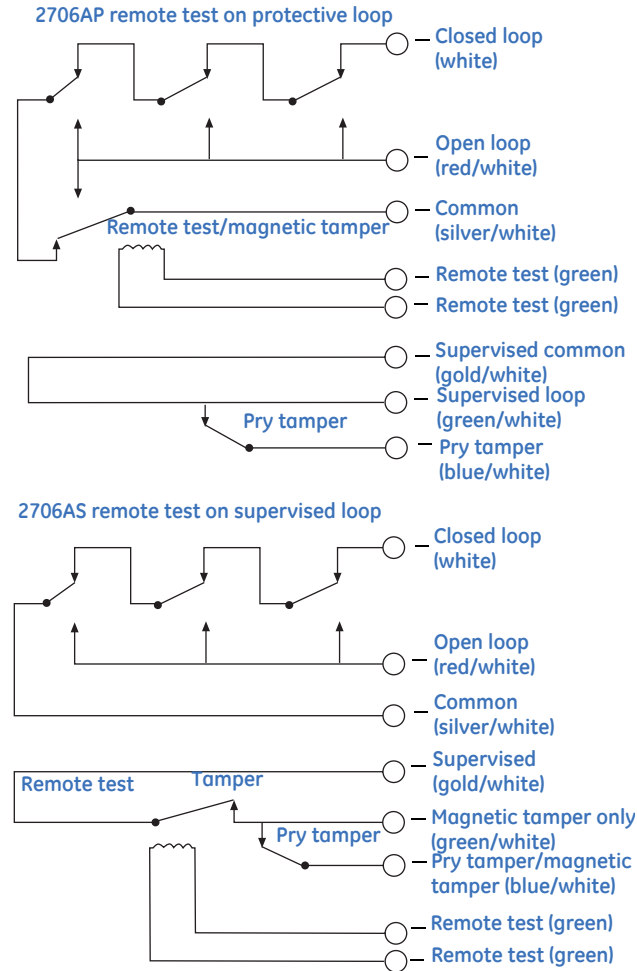

Note: Circuits shown with magnet in secure position.

Specifications

Part number	Loop type	Electrical configuration	Gap distance (make)*	Listings
2706AS	Open or closed	SPDT	0.2 to 0.6 in.	UL
2706AP	Open or closed	SPDT	0.2 to 0.6 in.	UL
2707A	Open or closed	SPDT	0.2 to 0.6 in.	UL
2707AD	Open or closed	DPDT	0.2 to 0.6 in.	UL

Lead type for all models: 3 in. stainless steel armored cable

*Gap distances are nominal make distance $\pm 20\%$

Electrical specifications

Form C (2747A)

Voltage: 30 VAC

Current: 0.25 A max.

Power: 3.0 W max.